



PT9 NINETY

UNDERWATER LOCATING DEVICE

Document number MA_Ninety_UserManual_Rev_6.0



Ninety User Manual

Novega Produktionssysteme GmbH

Gewerbepark 2 | 87477 Sulzberg (See) | Germany

Fon: +49/8376/92990-0 | Fax: +49/8376/92990-20

info@novega.de | www.novega-sea.com

PNR: PT9_NINETY

PNR Revision: 00

Cage Code: CG871



Issue No.: 6

Amendment No.: 0

 Novega Locate the difference	Document Title:	Ninety User Manual
	Document Name:	MA_Ninety_UserManual

Item Type: **Underwater Locating Device (ULD)**
 Item Name: **Underwater Locating Device**
 PNR: **PT9_NINETY**

Company: **Novega Produktionssysteme GmbH**
 Gewerbepark 2 | 87477 Sulzberg (See) | Germany
 Fon: +49/8376/92990-0 | Fax: +49/8376/92990-20
info@novega.de | www.novega.de

Activity	Name	Function	Department	Signature
Prepared:	Claudia Fellmann	Project Assistant	TD	
Released:	Florian Bader	Technical Manager	TD	

This document/data is the property of Novega. You may not possess, use, copy, or disclose this document/data or any information contained therein, for any purpose, including without limitation to design, manufacture, or repair parts, or obtain BSH or any other government approval to do so, without Novega express written permission. Neither receipt nor possession, use, copying, or disclosing by anyone without Novega express written permission is not authorized and may result in criminal and/or civil liability. This document/data remains the property of Novega. This document/data is not releasable under the "freedom of information act".

© Copyright by Novega Produktionssysteme GmbH all rights reserved.

Table 1-1: Authorizations Table

Issue No. 6	Amendment No. 0	Page 2 of 25
© Novega 2021, confidential and proprietary document		

	Document Title:	Ninety User Manual
	Document Name:	MA_Ninety_UserManual

1 Administration

1.1 Table of Contents

1	Administration.....	3
1.1	Table of Contents	3
2	Introduction.....	6
2.1	Log of Revisions	6
2.2	Definitions	7
2.3	Abbreviations	7
3	General	8
3.1	Description	8
3.2	Type Plate Example	9
3.3	Specification	10
3.4	SAE AS8045A Testing Qualification Summary	11
3.4.1	Equipment	11
3.5	Occurrence Report	12
4	Installation.....	13
4.1	Site Selection Guidance.....	13
4.2	Installation Procedures.....	13
4.2.1	General	13
4.2.2	Mounting.....	14
5	Operational and Battery Testing with Ulyser.....	15
5.1	General	15
5.2	Cleaning.....	15
5.3	Testing with the Novega Ulyser.....	15
6	Testing with TAG 2550 Tester	16
6.1	Service Operation Mode	16
6.2	Battery Voltage Measurement.....	17
6.3	Acoustic Test.....	17
7	Fault Isolation	18
8	Battery Replacement.....	20
8.1	General	20
8.2	Battery Replacement Equipment.....	20
8.3	Procedure of Battery Replacement.....	20

	Document Title:	Ninety User Manual
	Document Name:	MA_Ninety_UserManual

9	Long-Term Storage	23
10	Transportation Temperature Range.....	23
11	Surface Coating.....	23
12	Illustrated Parts List.....	24
13	End of Service Life	25
14	Returns	25
14.1	Service Address	25
15	Warranty and Guaranty.....	25
16	CE-Conformity	25

	Document Title:	Ninety User Manual
	Document Name:	MA_Ninety_UserManual

List of Figures

Figure 1: PT9 NINETY 8

Figure 2: Type Plate Example 9

Figure 3: ULD Dimensions 10

Figure 4: Ulyser..... 15

Figure 5: Service Operation Mode 16

Figure 6: Battery Voltage Measurement..... 17

Figure 7: Opening the ULD 21

Figure 8: Remove the Battery..... 21

Figure 9: Illustrated Parts 24

List of Tables

Table 1-1: Authorizations Table 2

Table 2-1: Log of Revisions 6

Table 3-1: Specification 10

Table 3-2: Test Qualification Summary Equipment..... 12

Table 7-1: Fault Isolation 19

Table 12-1: Illustrated Parts List..... 24

	Document Title:	Ninety User Manual
	Document Name:	MA_Ninety_UserManual

2 Introduction

This manual contains the description, as well as the installation and maintenance directions for the PT9 NINETY Underwater Locating Device. The nautical equipment Underwater Locating Device (ULD) / PT9 Ninety have been type examination tested and meet or exceed all applicable requirements of the SAE AS8045A:2011 and IEC 61996, Ed.2:2013 (Voyage Date Recorder).

Note: This manual must be read to its full extent prior to any initiation or operation, testing or maintenance of the Underwater Locating Device PT9 NINETY.

2.1 Log of Revisions

The following table summarizes the issue and amendment level evolution, tracing the changes in the affected paragraphs.

Issue	Amendment	Date	Description	Affected paragraphs
1	0	01 Apr 2014	external form / arrangement	-
2	0	16 Jun 2014	enable serial number assignment	
3	0	01 Aug 2014	external form / arrangement	-
4	0	05 Nov 2014	Expl. original battery inserted	-
5	0	20 Jan 2015	Type plate / original battery inserted	-
6	0	13 Aug 2021	external form / arrangement	-

Table 2-1: Log of Revisions

	Document Title:	Ninety User Manual
	Document Name:	MA_Ninety_UserManual

2.2 Definitions

“Additional unapproved stamps or labels” means any marking other than the original type labels as shown in Figure 1.

“Beacon” in this document has the same meaning as ULD.

“Sleep mode current” means the current which is required to power the internal micro-controller while the ULD is not activated.

“Activated” means the ULD is transmitting 37.5 kHz pulses every second.

“Revalidation” means battery replacement of the ULD.

“Multimeter” or a “Multitester”, is an electronic measuring instrument that combines several measurement functions in one unit. A typical multimeter can measure voltage, current, and resistance.

“Signal” means an acoustic sound emitted by the ULD.

“Pulse” in this document has the same meaning as signal.

“Operating / transport temperature range” is the environmental temperature range which the ULD can be exposed to either installed on ship or during transportation.

“Operating Temperature” is the minimum temperature range in which a submerged ULD must activate and emit an acoustic signal for 90 days in order to utilize in finding recorders or ship.

“Operating life” is the minimum number of days the ULD will emit an acoustic signal when submerged.

2.3 Abbreviations

- BSH Federal Office for maritime navigation and hydrography
- PNR Equipment Part Number
- SAE AS8045A Minimum Performance Standard for Underwater Locating Devices

	Document Title:	Ninety User Manual
	Document Name:	MA_Ninety_UserManual

3 General

3.1 Description

The PT9 NINETY Underwater Locating Device (ULD) is battery-powered and primarily consists of an electronic module and a signal transmitter. Protected by a cylindrical, water- and weatherproof housing, the ULD withstands extreme environmental conditions, high G-impact shock and deep sea - pressure up to 6096 m. The ULD is activated by immersion into fresh- or salt-water. The activation effects the emission of a defined acoustic signal (37.5 kHz). The battery capacity is dimensioned in such a way that the ULD is able to send this acoustic signal for the duration of at least 90 days.



Figure 1: PT9 NINETY

Note: Differences of the housing and the cap in terms of colour and lustre are related to the coating process and do not demonstrate any loss of corrosion resistance or damage.

	Document Title:	Ninety User Manual
	Document Name:	MA_Ninety_UserManual

3.2 Type Plate Example

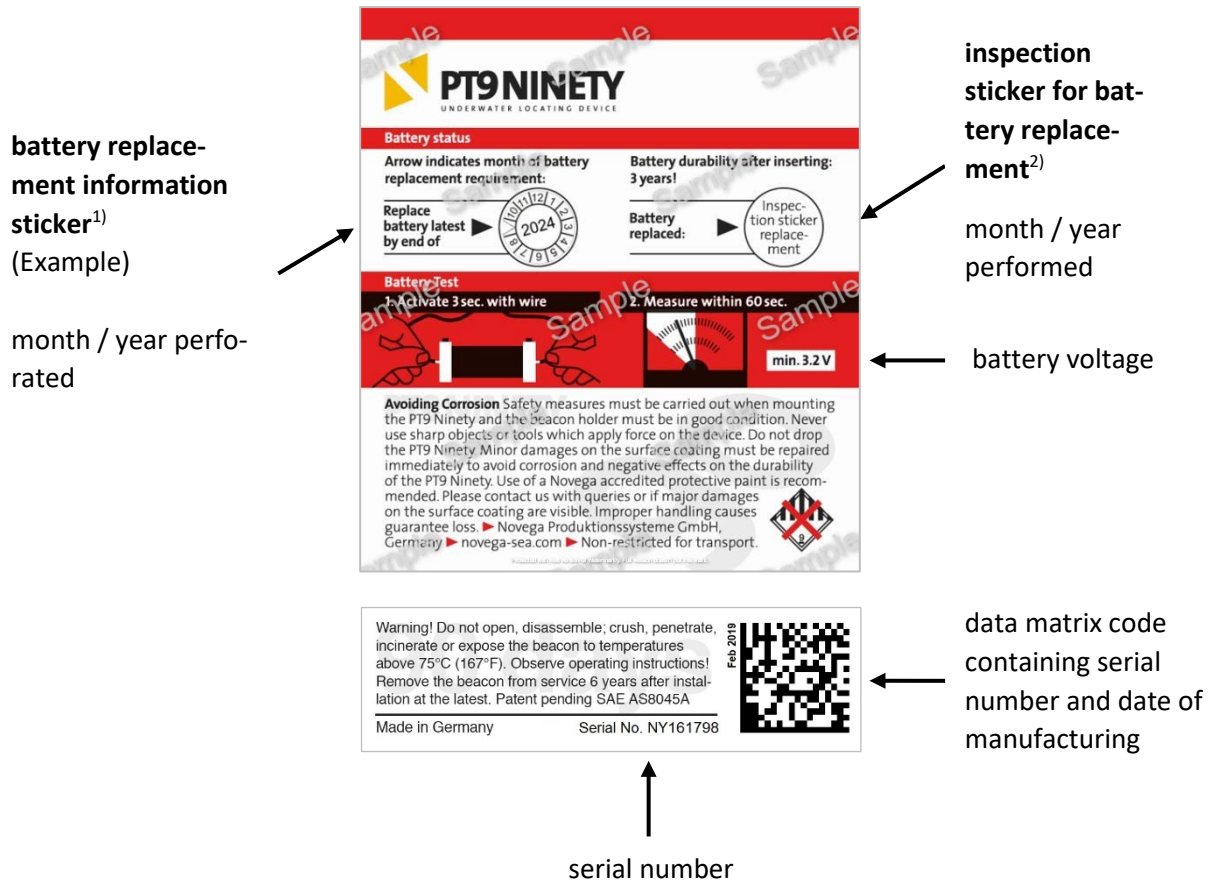



Figure 2: Type Plate Example

¹⁾ **Note:** The battery replacement information sticker indicates the expiration date of the beacon/battery. The marked battery replacement information sticker is positioned in such a way that the arrow points to the month whose end corresponds to the expiration date of the beacon/battery. At this date, the battery must be replaced at latest.

²⁾ **Note:** The inspection sticker indicates the date the battery was replaced. The inspection sticker is positioned in such a way that the arrow points to the month of the battery replacement. Three years after this date, the lifetime of the beacon expires.

 Locate the difference	Document Title:	Ninety User Manual
	Document Name:	MA_Ninety_UserManual

3.3 Specification

Operating Frequency:	37.5 kHz +/- 1 kHz
Operating Depth:	6.096 m (~ 20.000 ft)
Operating life:	90 days (Minimum)
Operating / transport temperature range:	-55°C (-67°F) to +75°C (+167°F)
Pulse length:	9 ms (Minimum)
Pulse repetition rate:	0.9 pulses/s
Battery life cycle:	3 years
Acoustic output, initial:	min. 160.5 dB vs 1 µPa at 1 metre (106 N/m ²)
Acoustic output after 90 days:	min. 157 dB vs 1 µPa at 1 metre (70 N/m ²)
Radiation pattern:	min. 80% of a sphere
Activation:	Fresh- or Salt water
Length:	see Figure 3: ULD Dimensions
Diameter:	see Figure 3: ULD Dimensions
Weight:	187 g (6.6 oz)

Table 3-1: Specification

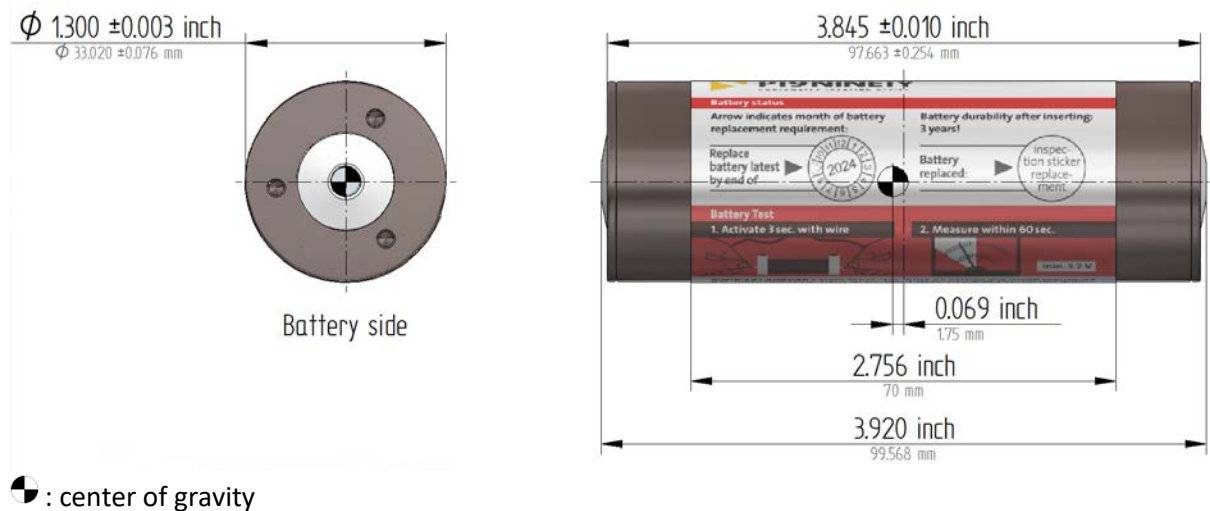

Figure 3: ULD Dimensions

	Document Title:	Ninety User Manual
	Document Name:	MA_Ninety_UserManual

3.4 SAE AS8045A Testing Qualification Summary

3.4.1 Equipment

The beacon is designed to meet the performance specifications of SAE AS8045A. A summary of the testing qualifications is presented in the table below.

Conditions	Tests	Description
------------	-------	-------------

GENERAL STANDARDS		
Material	SAE AS8045A § 3.1	-
Workmanship	SAE AS8045A § 3.2	-
Compatibility	SAE AS8045A § 3.3	-
Interchangeability	SAE AS8045A § 3.4	-
Flammability and Fire Test	SAE AS8045A § 3.5	-
Power Source	SAE AS8045A § 3.6	-
Identification	SAE AS8045A § 3.7	-

MINIMUM PERFORMANCE STANDARDS		
Actuation	SAE AS8045A § 4.1	fresh- and salt water at all depths from 0.15 m (0.5 ft) to 6096 m (20 000 ft) within 4 h
Operating Temperature	SAE AS8045A § 4.2	-2 °C (+28 °F) to +38 °C (+100 °F)
Radiation Pattern	SAE AS8045A § 4.3	80% of a spherical pattern
Operating Frequency	SAE AS8045A § 4.4	37.5 ± 1 kHz
Pulse Length	SAE AS8045A § 4.5	9.0 ms MINIMUM
Repetition Rate	SAE AS8045A § 4.6	0.9 pulse/s MINIMUM
Operating Life = §5.13	SAE AS8045A § 4.7	90 days
Initial Operation	SAE AS8045A § 4.8.1	106 N/m ² (1060 dyne/cm ²) r.m.s. pressure normalized to 1 metre range, that is, at a level of 160.5 dB vs 1 µPa at 1 metre
Immediately after 90 Days Continuous Operation	SAE AS8045A § 4.8.2	70 N/m ² (700 dyne/cm ²) r.m.s. pressure normalized at 1 metre range, that is, at a level of 157 dB vs 1 µPa at 1 metre

 Locate the difference	Document Title:	Ninety User Manual
	Document Name:	MA_Ninety_UserManual

TEST PROCEDURES (ENVIRONMENTAL)
--

Condensation	SAE AS8045A § 5.1	cold soak at -9 ± 3 °C ($+16 \pm 5$ °F) for 6 hours and then at $+35 \pm 3$ °C ($+95 \pm 5$ °F) at a relative humidity of $95 \pm 5\%$ for 18 hours
Temperature Storage	SAE AS8045A § 5.2	RTCA/DO-160G Section 4.5 Category D2
Temperature Variation	SAE AS8045A § 5.3	RTCA/DO-160G Section 5 Category A -55 °C (-67 °F) and $+70$ °C ($+158$ °F)
Vibration	SAE AS8045A § 5.4	RTCA/DO-160G Section 8; Fig. 8-4, Curve C1; Table 8-2b, Curve G
Altitude, Decompression and Overpressure	SAE AS8045A § 5.5	RTCA/DO-160G Section 4.6 Category D2
Fluid Immersion	SAE AS8045A § 5.6	RTCA/DO-160G Section 11 Category F
Induced Signal Susceptibility	SAE AS8045A § 5.7	RTCA/DO-160G Section 19 Category ZC
Magnetic Effect	SAE AS8045A § 5.8	RTCA/DO-160G Section 15 Category Z
Sand and Dust	SAE AS8045A § 5.9	RTCA/DO-160G Section 12 Category S
Salt Spray (Salt Fog)	SAE AS8045A § 5.10	RTCA/DO-160G Section 14 Category S/T
Fungus Resistance	SAE AS8045A § 5.11	RTCA/DO-160G Section 13 Category F
Salt Water Immersion	SAE AS8045A § 5.13	90 days; $+10$ °C ($+50$ °F) and $+21$ °C ($+70$ °F)

PERFORMANCE VERIFICATION (ENVIRONMENTAL)

Performance Verification	SAE AS8045A § 5.12	after 5.1 - 5.11 the ULD shall meet all the requirements of Section 4
--------------------------	--------------------	---

TEST PROCEDURES (CRASH SURVIVABILITY)
--

Impact Shock	SAE AS8045A § 6.1	1000 g (gravity) / 5 ms applied to each of the three orthogonal axes
Impact	SAE AS8045A § 6.2	25 kg (55 lb) from 150 mm (6.0 inches)
Static Crush	SAE AS8045A § 6.3	22.4 kN (5000 lbf) for 5 min
Pressure	SAE AS8045A § 6.4	60 MPa (600 bar; 8700 lbf/in ²) for 5 min

PERFORMANCE VERIFICATION (CRASH SURVIVABILITY)

Performance Verification	SAE AS8045A § 7	after 6.1 - 6.4 the ULD shall meet all the requirements of Section 4
--------------------------	-----------------	--

Table 3-2: Test Qualification Summary Equipment

3.5 Occurrence Report

For reporting of any occurrence related to a Novega authorised equipment, the following mail-address info@novega.de shall be used.

	Document Title:	Ninety User Manual
	Document Name:	MA_Ninety_UserManual

4 Installation

This section describes the methodical installation and mounting of the Underwater Locating Device.

4.1 Site Selection Guidance

Note: The following considerations should be taken into account as a guidance, but under no circumstances do constitute an installation advice.

The ULD installation should not hinder the removal/installation or servicing of other equipment. Installation of the ULD should provide enough space to:

- Perform required maintenance activities, e.g. check of ULD battery or functional test of the ULD without removal of the ULD from its bracket.
- Permit the qualified technician to work with both hands while observing the work area.

The ULD label should be readable without the use of special tooling or removal of the ULD from its bracket.

The selection of the mounting location and the orientation should ensure that the ULD is not likely to activate due to fluids accumulation during normal use. Any compartment that may be expected to flood easily during normal use should not be selected. Direct contact between the ULD's water sensitive switches and water may activate the acoustic signal output.

The installation area of the ULD must be free of sound absorbent materials (honeycomb structures, tarpaulins and persennings, clothes, cargo, etc.) to avoid the possibility that ULD transmissions are attenuated significantly. Do not wrap round the ULD with tape or insulation blankets. Do not impure the ULD with paint or primers.

In case of an incident, the possibility of demolition of the unit by crash is to be minimized. The environment, selected for mounting the ULD, has to exclude the possibility that the ULD can be struck by moving, heavy weight components.

The ULD must not be disassembled, crushed, penetrated, incinerated or exposed to temperatures above +75°C (+167°F).

4.2 Installation Procedures

4.2.1 General

Before installing the ULD, please consider that the ULD can be properly tested once it is installed.

- Before installing the ULD, ensure that the contact surfaces between ULD and mounting bracket are flat, coated, without sharp-edged areas, free of impurities and rust.
- Inspect the ULD for transportation damages.
- Additional unapproved stamps or labels on the ULD may reduce the acoustic radiation.

Note: In case of doubt, or if the ULD should show damages, please contact our service department ([Service Address](#)).

Issue No. 6	Amendment No. 0	Page 13 of 25
© Novega 2021, confidential and proprietary document		

	Document Title:	Ninety User Manual
	Document Name:	MA_Ninety_UserManual

4.2.2 Mounting

Dependant of the recorder manufacturer different mounting bracket may be used. Please follow the mounting instructions of the recorder manufactures manual and approved procedures and hardware. Prevent distortion of the ULD while mounting on the mounting bracket.

Note: Safety measures must be carried out when mounting the PT9 Ninety and the beacon holder must be in good condition. Never use sharp objects or tools which apply force on the device. Do not drop the Pt9 Ninety. Minor damages on the surface coating must be repaired immediately to avoid corrosion and negative effects on the durability of the PT9 Ninety. Use of a Novega accredited protective paint is recommended. Improper handling causes guarantee loss.

	Document Title:	Ninety User Manual
	Document Name:	MA_Ninety_UserManual

5 Operational and Battery Testing with Ulyser

5.1 General

After its installation, we recommend to test the ULD. When the ULD is installed at its place of use the minimum schedule for beacon cleaning and testing is every 12 months. The ULD is to be cleaned and tested by a qualified service technician.

5.2 Cleaning

Even though the ULD is equipped with a protection against unintentional activation, both of the pins are to be kept clean and impurities are to be removed. Clean the water switch pins and the housing with a soft cloth and a mild detergent, and then dry them carefully with a clean cloth. Clean the white insulations around the water switch pin as well, to reach an optimum dripping performance of wetting fluids. The water switch pins are to be cleaned whenever dirt or dust accumulate.

5.3 Testing with the Novega Ulyser

The Ulyser is the state-of-the-art device to test and analyze all Novega ULD's. All necessary tasks are performed quickly and easily. The Ulyser is a battery-powered receiver for ultrasonic signals with a frequency of 5 to 50 kHz. Protocol files of ULD's can be read out and analyzed. The Ulyser receives ultrasonic signals via an integrated microphone. The received signals are optically reflected by a blinking symbol and acoustically via an integrated loudspeaker.

For further instructions and the complete testing procedure please follow the instructions of the Ulyser manual.



Figure 4: Ulyser

6 Testing with TAG 2550 Tester

For a complete functional test, the TAG 2550 Tester and a high impedance multimeter is required.

- Use the Novega TAG 2550 Tester for the acoustic signal test. **Please consider, that therefore the ULD has to be set into service operation mode (see 6.1).**

Note: For further instructions and the complete testing procedure please follow the instructions of the TAG 2550 Tester manual.

- For battery voltage measurement, use a high impedance multimeter (impedance 10 MΩ). **Please consider, that therefore the ULD has to be set into service operation mode (see 6.1).**

Note: Instructions for use of a multimeter are not specified further in this manual.

6.1 Service Operation Mode

Please ensure that both water switch pins are clean and dry before starting the test (following 5.1 and 5.2).

Note: The ULD contains an intelligent activation, which avoids an unintentional activation, whereby the durability of the battery could be impaired. On this account, observe the following procedure to set the ULD into the service operation mode.

Connect both of the water switch pins for approx. 3 seconds with the wire jumper (strap of the TAG 2550 Tester), this sets the ULD into the service operation mode. The ULD is in the service operation mode for 60 seconds now. At this point, the battery voltage is circulating to the water switch pins and the ULD is pulsing the acoustic signal. After expiration of 60 seconds, the ULD drops back into the sleep mode.

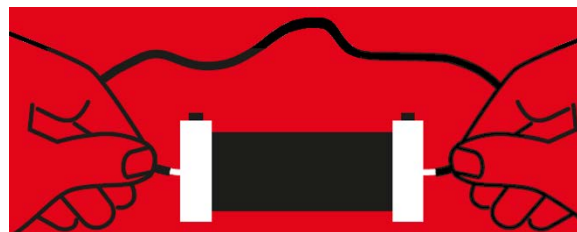

connect for 3 sec. with wire jumper

Figure 5: Service Operation Mode

	Document Title:	Ninety User Manual
	Document Name:	MA_Ninety_UserManual

6.2 Battery Voltage Measurement

Adjust the multimeter into a range of 20 V DC. During the 60 seconds, press both of the multimeter test prods on the ULD water switch pins and read off the battery voltage.



Figure 6: Battery Voltage Measurement

The indication of the multimeter might oscillate in the decimal range. This is normal and shows, that the ULD is pulsing the acoustic signal, which causes a minor fall of voltage. The minimum read-out voltage value must not fall below 3.2 V. If minimum value is undercut, the beacon/battery must be replaced.

6.3 Acoustic Test

Perform the acoustic test with the TAG 2550 Tester, please ensure that the ULD is in the service operation mode (see 6.1).

If battery voltage is in order but no signal is received, please read the fault isolation instructions (see 7) or contact our service department ([Service Address](#)).

	Document Title:	Ninety User Manual
	Document Name:	MA_Ninety_UserManual

7 Fault Isolation

Caution: An ULD with a voltage of 0 V and/or no signal, points out to either a problem with setting the ULD into the Service Operation Mode or a failure of the battery (not anticipated). In both events, do not open the ULD as it might be under pressure! Please contact our service department ([Service Address](#)) for further assistance.

Faults you can find during testing are given here under together with their probable causes and their corrective actions. After the necessary corrective action is done, please repeat the test to make sure that the fault is corrected.

Fault	Probable Cause	Correction Action
Testing with the Novega Ulyser does not deliver the expected result.	For fault isolation and the complete testing procedure with the Novega Ulyser please follow the instructions of the Ulyser manual.	
The ULD shows 0 V on the functional test (testing with TAG 2550 Tester and multimeter).	The ULD is not in "Service Operation Mode".	Switch the ULD in the "Service Operation Mode", refer to Service Operation Mode .
	Defective multimeter.	Replace the multimeter.
	Incorrect adjustment of the multimeter.	Adjust the Multimeter correctly.
	Bad contact on the Water Switch Pins.	Clean the Water Switch Pins, refer to Cleaning .
	End of the Service Operation Mode and therefore the end of the 60 seconds, where the measuring is possible, is reached.	Switch the ULD again in the "Service Operation Mode", refer to Service Operation Mode .
	Defect of the ULD.	Do not open, please contact our Service Address .
	ULD battery is defective.	Do not open, please contact our Service Address .
The ULD shows on the functional test less voltage than the required 3.2 V.	The ULD is not in "Service Operation Mode".	Switch the ULD in the "Service Operation Mode", refer to Service Operation Mode .
	Defective multimeter.	Replace the multimeter.
	Incorrect adjustment of the multimeter.	Adjust the Multimeter correctly.
	Bad contact on the Water Switch Pins.	Clean the Water Switch Pins, refer to Cleaning .
	End of the Service Operation Mode.	Switch the ULD again in the "Service Operation Mode", refer to Service Operation Mode .
	Defect of the ULD.	Please contact our Service Address .
	ULD battery is discharged.	Replace the battery, refer to Battery Replacement .
No acoustic signal of the ULD.	The ULD is not in "Service Operation Mode".	Switch the ULD in the "Service Operation Mode", refer to Service Operation Mode .

 Locate the difference	Document Title:	Ninety User Manual
	Document Name:	MA_Ninety_UserManual

Fault	Probable Cause	Correction Action
	The frequency of 37.5 kHz is not audible.	Use the test device "Ulyser" or "TAG 2550 Tester", to receive the acoustic signal in the frequency range of 37.5 kHz.
	ULD battery low.	If battery voltage > 0 V, replace the battery, refer to Battery Replacement . If battery voltage is 0 V, do not open and please contact our Service Address .
	Defect of the ULD.	Please contact us.
ULD cannot be switched to "Service Operation Mode".	Bad contact on the Water Switch Pins.	Clean the Water Switch Pins, refer to Cleaning .
	Insufficient conductivity of the connection between the poles.	Check if the wire jumper to connect both of the water switches has a resistance below 1 kOhm.
	Defect of the ULD.	Please contact our Service Address .
Displayed voltage value on the multimeter oscillates in the decimal range.	This is normal and shows that the ULD is pulsing the acoustic signal, which causes a minor fall of voltage, however the minimum read-out voltage value shall not fall below 3.2 Volt.	No fault if value does not undercut the minimum value of 3.2 Volts.
The battery voltage can be read out, but there is no acoustic sound.	The frequency of 37.5 kHz is not audible.	Use the test device "Ulyser" or "TAG 2550 Tester", to receive the acoustic signal in the frequency range of 37.5 kHz.
	Defect of the ULD.	Please contact our Service Address .
Battery replacement information sticker is missing/not readable.	The location of the battery replacement information sticker is explained in Figure 2: Type Plate Example.	If the battery replacement information sticker is missing or not readable, please contact our Service Address for further assistance.

Table 7-1: Fault Isolation

	Document Title:	Ninety User Manual
	Document Name:	MA_Ninety_UserManual

8 Battery Replacement

8.1 General

Disassembly of the ULD is limited to the battery replacement.

Warning: Incorrect installation of the battery will cause permanent damage to the ULD.

Note: We recommend that the battery replacement should be done by a qualified technician. When opening the ULD, strictly follow the instructions below! Opening of the device without original tools and replacement parts will void the guarantees and operating license!

Warning: The use of any other battery than PNR 18725-00 invalidates the BSH authorization and warranty.

Note: For further details regarding the battery, please contact our service department ([Service Address](#)).

8.2 Battery Replacement Equipment

Battery replacement kit (PNR 20297-00) consisting of:

- 1x Battery (PNR 18725-00)
- 1x O-Ring (PNR 16227-00)

Required tools:

- Torque 3.0 (PNR Torque 3.0)
- Pressure dispense clamp (PNR 17359-00)
- Ulyser (PNR 20538-00) or TAG 2550 Tester (PNR 17610)
- DC-Meter (PNR 20582-00)
- Multimeter (optional)

8.3 Procedure of Battery Replacement

a) Removal of the ULD

Remove the ULD from the mounting bracket.

b) Cleaning the ULD

Clean the ULD with a soft cloth (see 5.2).

c) Battery Voltage Check

According the procedures described above.

Caution: An ULD with a voltage of 0 V and/or no signal, points out to either a problem with setting the ULD into the Service Operation Mode or a failure of the battery (not anticipated). In both events, do not open the ULD as it might be under pressure! Please contact our service department ([Service Address](#)) for further assistance.

Issue No. 6	Amendment No. 0	Page 20 of 25
© Novega 2021, confidential and proprietary document		

d) Opening the ULD

Secure the beacon with the Pressure dispense clamp (PNR 17359-00). Use the Torque 3.0 to remove the battery cap, containing 3 boreholes, by unscrewing anti-clockwise. The breakaway torque is usually high, so the Torque wrench should be held firmly in contact with the battery cap to avoid damages at the wrench holes.

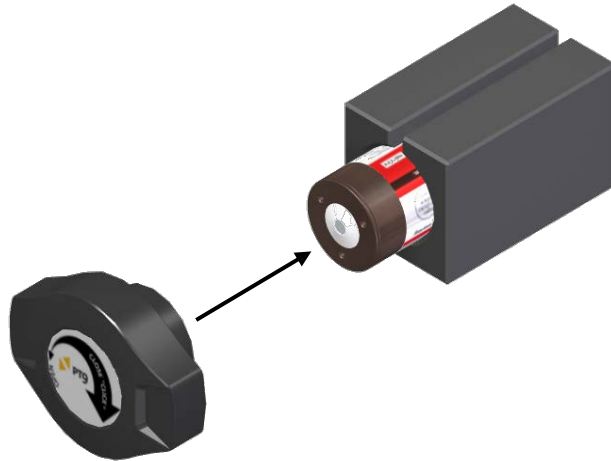

Figure 7: Opening the ULD

e) Removing the Battery

Remove the old battery by tilting the beacon.

Note: When the expiry date is reached, the battery should be disposed of in accordance with all local, state and federal regulations.

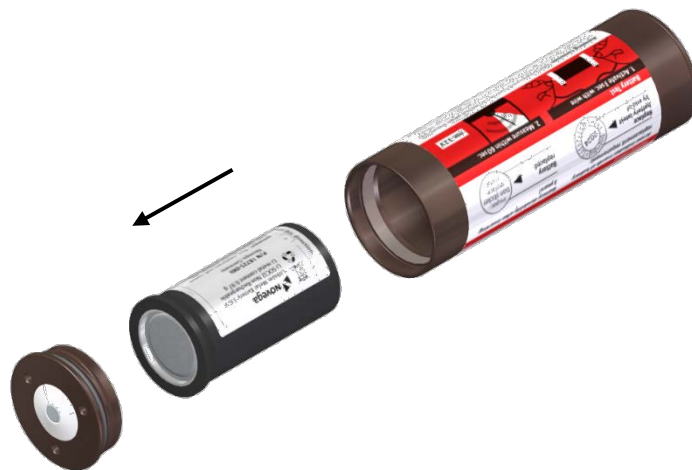



Figure 8: Remove the Battery

	Document Title:	Ninety User Manual
	Document Name:	MA_Ninety_UserManual

f) Check of the Sleep Mode Current

The DC-Meter (PNR 20582-00) is required to check the sleep mode current.

For further instructions and the complete testing procedure please follow the instructions of the DC-Meter manual.

Note: The sleep mode current shall be checked, as an increased sleep mode current may affect the ULD life time.

g) Installing the new Battery

Install the new battery.

Note: The battery provides protection against installation with incorrect polarity, however do not try to push the battery into the ULD with the bigger battery end first.

h) Installing the new O-Ring

Remove the old O-Ring from the battery cap. Clean the O-Ring groove, the thread on the cap and the thread on the housing and install the new O-Ring.

Note: To prevent damage to the O-Ring groove remove the old O-Ring very carefully.

i) Closing the ULD

Tighten the battery cap by hand and make use of the Torque 3.0 only for the final turns. Remove any excess lubricant from the exterior of the ULD.

Note: An audible “click” confirms the correct tightening torque of 3.0 Nm (2.2 lbf.ft).

j) Operational and Battery Test

For Operational and Battery Test see [chapter 5 or 6](#).

k) Battery Replacement Date

The battery replacement date is to be recorded on the ULD. Therefore, the inspection sticker for battery replacement is to be stucked on the relevant section of the type label ([see figure 2 in chapter 3.2](#)).

l) Mounting of the ULD

Mount the ULD in the order described under [chapter 4.2.2](#).

	Document Title:	Ninety User Manual
	Document Name:	MA_Ninety_UserManual

9 Long-Term Storage

When long-term storage of the ULD is required, the ULD should be stored in the original shipping container or adequate packaging.

Ensure that the ULD is stored at general warehouse conditions not exceeding +45°C (+113°F). The recommended long-term storage temperature should not exceed +30°C (+86°F). Avoid exposure to direct sunlight!

The maximum storage time for an ULD is three years. After three years, as indicated by the battery replacement information sticker, the battery has to be replaced (see 8).

10 Transportation Temperature Range

The transport temperature range should be between -55°C to +75°C (-67°F to +167°F).

For further information about the transport and relevant transport regulations, please contact our service department ([Service Address](#)).

11 Surface Coating

Please note that differences of the housing and the battery cap in terms of colour are coating specific and do not lead to any loss of corrosion resistance.

Issue No. 6	Amendment No. 0	Page 23 of 25
© Novega 2021, confidential and proprietary document		

12 Illustrated Parts List

No.:	Description	Part number	Quantity
	Underwater Locating Device	PT9_NINETY	-
10	Housing	23708-00	1
20	Battery	18725-00	1
30	Battery Cap	18724-00	1

Table 12-1: Illustrated Parts List

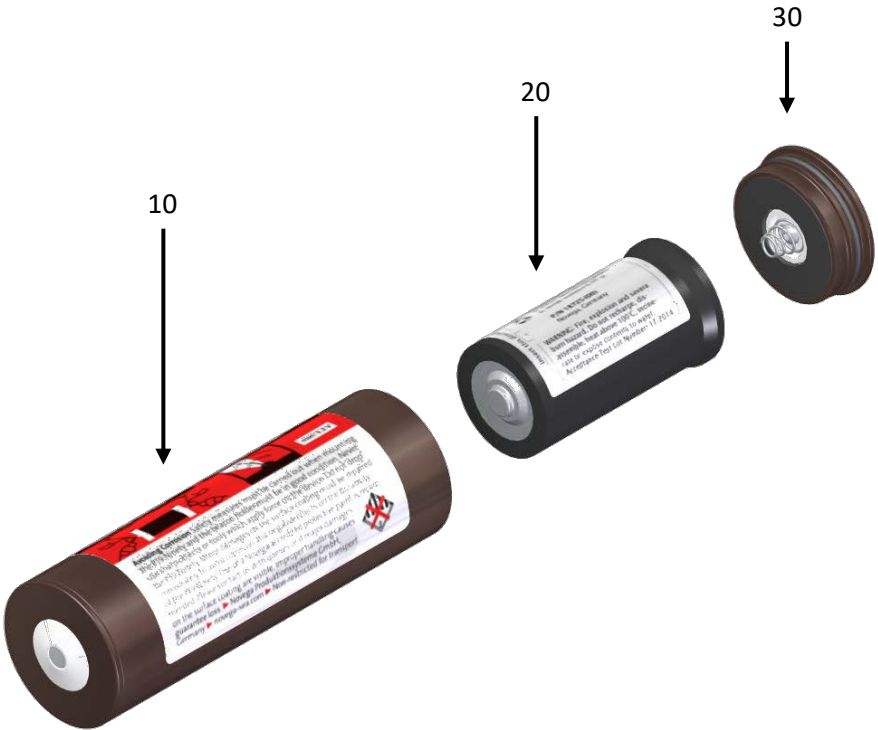

Figure 9: Illustrated Parts

	Document Title:	Ninety User Manual
	Document Name:	MA_Ninety_UserManual

13 End of Service Life

The number of possible revalidations is limited to one battery replacement. However, revalidation is only possible if the ULD is in good and undamaged condition with full functionality.

If revalidation is not possible, the ULD must be taken out of service and disposed of in accordance with all local, state and federal regulations.

For further information regarding the end of service life, please contact our service department ([Service Address](#)).

14 Returns

Please contact our service department ([Service Address](#)) for clearing the details and planning before returning the beacon.

Required Information:

- Reason for the return
- Serial number of the acoustic beacon
- Order (if required) for replacement of the ULD
- Company
- Contact Data (name, telephone, e-Mail address)

14.1 Service Address

Novega Produktionssysteme GmbH

Gewerbepark 2 | 87477 Sulzberg (See) | **Germany**

Fon: (+49) 8376-92990-0

Fax: (+49) 8376-92990-20

E-Mail: info@novega.de

www.novega-sea.com

15 Warranty and Guaranty

For further information regarding warranty and guaranty, please contact our service department ([Service Address](#)).

16 CE-Conformity



This ULD meets the requirements of the EU-Directives for CE marking.

Issue No. 6	Amendment No. 0	Page 25 of 25
© Novega 2021, confidential and proprietary document		